

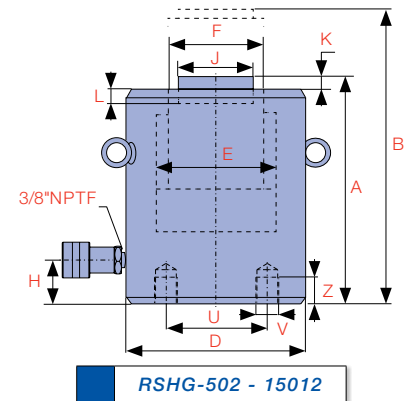

THE RSHG-SERIES IS A SINGLE ACTING LOAD RETURN HIGH TONNAGE CYLINDER RANGE UP TO 1,000 TON CAPACITY.

These cylinders feature a hard chrome cylinder bore and piston rod for maximum corrosion resistance and bronze overlay piston bearing area to resist side load induced damage. They are ideally suited for use in civil construction, heavy jacking and other high load applications. A built in stop ring ensures maximum performance and safety. Interchangeable hardened grooved saddles are standard and TSG tilt saddles are optional. All cylinders in this range have base mounting holes plus top and side mounted eye bolts for lifting and positioning.



Model Number	Cylinder Capacity ton* / kN	Stroke (mm)	Cylinder Effective Area (cm ²)	Oil Capacity (cm ³)	A Collapsed Height (mm)	B Extended Height (mm)	D Outside Diameter (mm)	E Cylinder Bore Diameter (mm)	F Piston Rod Diameter (mm)	H Base to Advance Port (mm)
RSHG-502	50	539	77.0	385	162	212	130	99.0	70.1	52
RSHG-504		539	77.0	769	212	312	130	99.0	70.1	52
RSHG-506		539	77.0	1,154	262	412	130	99.0	70.1	52
RSHG-508		539	77.0	1,539	312	512	130	99.0	70.1	52
RSHG-5010		539	77.0	1,923	363	613	130	99.0	70.1	52
RSHG-5012		539	77.0	2,308	412	712	130	99.0	70.1	52
RSHG-1002	100	929	132.7	663	182	232	165	130.0	95.0	54
RSHG-1004		929	132.7	1,327	232	332	165	130.0	95.0	54
RSHG-1006		929	132.7	1,990	282	432	165	130.0	95.0	54
RSHG-1008		929	132.7	2,653	332	532	165	130.0	95.0	54
RSHG-10010		929	132.7	3,317	382	632	165	130.0	95.0	54
RSHG-10012		929	132.7	3,980	432	732	165	130.0	95.0	54
RSHG-1502	150	1,390	198.6	992	196	246	205	159.0	114.1	61
RSHG-1504		1,390	198.6	1,985	246	346	205	159.0	114.1	61
RSHG-1506		1,390	198.6	2,977	296	446	205	159.0	114.1	61
RSHG-1508		1,390	198.6	3,969	346	546	205	159.0	114.1	61
RSHG-15010		1,390	198.6	4,961	396	646	205	159.0	114.1	61
RSHG-15012		1,390	198.6	5,954	446	746	205	159.0	114.1	61

* Nominal Cylinder Capacity in ton - see kN values for actual capacity

PISTON ROD WIPER

reduces contaminants

HARD CHROME PLATED BORE

for maximum corrosion resistance and cylinder life

HARD CHROME PLATED PISTON ROD

for maximum corrosion resistance and cylinder life

BRONZE OVERLAY

on the piston bearing area reduces side load induced damage and extends cylinder life

BASE MOUNTING

holes on all models

HARDENED GROOVED SADDLE

to prevent piston rod damage. Optional tilt saddles available

STOP RING

withstands full dead end loading

POWDER COATED FINISH

enhances appearance and reduces corrosion

PARKER

industry standard high flow coupling for compatibility



CAPACITY

50 - 1,000 ton

STROKE

50 - 300 mm

MAXIMUM OPERATING PRESSURE

700 bar

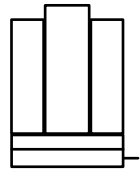

B

CYLINDERS

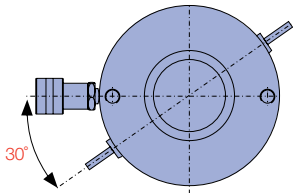

RSHG-502 - 15012

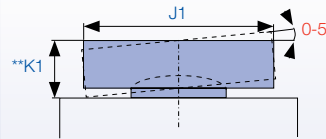

J Standard Saddle Diameter (mm)	K Saddle Protrusion from Piston Rod (mm)	L Depth of Piston Rod Hole (mm)	Base Mounting Holes			Weight (kg)	Optional Tilt Saddle			Model Number	Handle Type
			U Bolt Circle Diameter (mm)	V Thread	Z Thread Depth (mm)		Model Number	J1 Diameter (mm)	**K1 Height (mm)		
50	1	19	65	M12x1.75	22	17.0	TSG-50	50	43	RSHG-502	◆
50	1	19	65	M12x1.75	22	20.0	TSG-50	50	43	RSHG-504	◆
50	1	19	65	M12x1.75	22	23.0	TSG-50	50	43	RSHG-506	◆
50	1	19	65	M12x1.75	22	27.0	TSG-50	50	43	RSHG-508	◆
50	1	19	65	M12x1.75	22	31.0	TSG-50	50	43	RSHG-5010	◆
50	1	19	65	M12x1.75	22	34.0	TSG-50	50	43	RSHG-5012	◆
75	1	19	95	M12x1.75	22	19.0	TSG-100	75	48	RSHG-1002	◆
75	1	19	95	M12x1.75	22	29.0	TSG-100	75	48	RSHG-1004	◆
75	1	19	95	M12x1.75	22	40.0	TSG-100	75	48	RSHG-1006	◆
75	1	19	95	M12x1.75	22	50.0	TSG-100	75	48	RSHG-1008	◆
75	1	19	95	M12x1.75	22	61.0	TSG-100	75	48	RSHG-10010	◆
75	1	19	95	M12x1.75	22	71.0	TSG-100	75	48	RSHG-10012	◆
94	1	19	130	M12x1.75	22	39.0	TSG-150	94	50	RSHG-1502	◆
94	1	19	130	M12x1.75	22	52.0	TSG-150	94	50	RSHG-1504	◆
94	1	19	130	M12x1.75	22	65.0	TSG-150	94	50	RSHG-1506	◆
94	1	19	130	M12x1.75	22	78.0	TSG-150	94	50	RSHG-1508	◆
94	1	19	130	M12x1.75	22	92.0	TSG-150	94	50	RSHG-15010	◆
94	1	19	130	M12x1.75	22	105.0	TSG-150	94	50	RSHG-15012	◆

HANDLE TYPES: ♠ WELDED ◆ EYEBOLT ♥ REMOVABLE STRAP HANDLE ♣ THREAD

** Total cylinder collapsed height with optional tilt saddle equals (dim.A - dim.K + dim.K1)

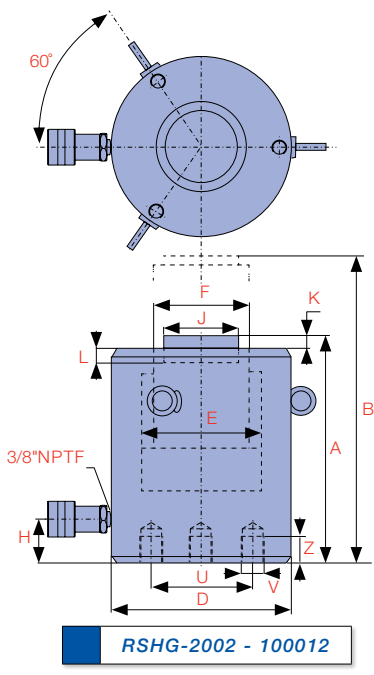

Did you know...

Durapac offer power units suitable for operating high tonnage cylinders. Models available include split flow synchronised and high flow single speed up to 8.1 Lpm at 700 bar.



Model Number	Cylinder Capacity ton* / kN	Stroke (mm)	Cylinder Effective Area (cm ²)	Oil Capacity (cm ³)	A Collapsed Height (mm)	B Extended Height (mm)	D Outside Diameter (mm)	E Cylinder Bore Diameter (mm)	F Piston Rod Diameter (mm)	H Base to Advance Port (mm)	
RSHG-2002	200	1,861	50	265.9	1,329	216	266	235	184.0	133.1	67
RSHG-2006		1,861	150	265.9	3,987	316	466	235	184.0	133.1	67
RSHG-20012		1,861	300	265.9	7,973	466	766	235	184.0	133.1	67
RSHG-2502	250	2,565	50	366.4	1,831	235	285	275	216.0	165.1	73
RSHG-2506		2,565	150	366.4	5,494	335	485	275	216.0	165.1	73
RSHG-25012		2,565	300	366.4	10,987	485	785	275	216.0	165.1	73
RSHG-3002	300	3,193	50	456.2	2,280	312	362	310	241.0	197.1	101
RSHG-3006		3,193	150	456.2	6,839	412	562	310	241.0	197.1	101
RSHG-30012		3,193	300	456.2	13,678	562	862	310	241.0	197.1	101
RSHG-4002	400	3,919	50	559.9	2,798	375	425	350	267.0	215.9	114
RSHG-4006		3,919	150	559.9	8,394	475	625	350	267.0	215.9	114
RSHG-40012		3,919	300	559.9	16,789	625	925	350	267.0	215.9	114
RSHG-5002	500	5,114	50	730.6	3,651	419	469	400	305.0	247.9	114
RSHG-5006		5,114	150	730.6	10,954	519	669	400	305.0	247.9	114
RSHG-50012		5,114	300	730.6	21,907	669	969	400	305.0	247.9	114
RSHG-6002	600	5,987	50	855.3	4,274	429	479	430	330.0	267.0	114
RSHG-6006		5,987	150	855.3	12,823	529	679	430	330.0	267.0	114
RSHG-60012		5,987	300	855.3	25,646	679	979	430	330.0	267.0	114
RSHG-8002	800	8,234	50	1,176.3	5,878	474	524	505	387.0	317.0	149
RSHG-8006		8,234	150	1,176.3	17,635	574	724	505	387.0	317.0	149
RSHG-80012		8,234	300	1,176.3	35,271	724	1,024	505	387.0	317.0	149
RSHG-10002	1,000 [†]	10,260	50	1,465.7	7,325	564	614	560	432.0	342.9	174
RSHG-10006		10,260	150	1,465.7	21,975	664	814	560	432.0	342.9	174
RSHG-100012		10,260	300	1,465.7	43,950	814	1,114	560	432.0	342.9	174

* Nominal Cylinder Capacity in ton - see kN values for actual capacity

[†] Tilt saddle supplied as standard

Did you know...

Low collapsed height *RSH-Series* cylinders are available.



CAUTION...

Mounting Hole Orientation
Top mounting hole orientation is maintained to port location.
Base mounting hole orientation is *not* maintained to port location.



B

CYLINDERS

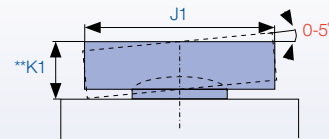

J Standard Saddle Diameter (mm)	K Saddle Protrusion from Piston Rod (mm)	L Depth of Piston Rod Hole (mm)	Base Mounting Holes			Weight (kg)	Optional Tilt Saddle			Model Number	Handle Type
			U Bolt Circle Diameter (mm)	V Thread	Z Thread Depth (mm)		Model Number	J1 Diameter (mm)	**K1 Height (mm)		
113	1	24	165	M12x1.75	22	55.0	TSG-200	113	59	RSHG-2002	◆
113	1	24	165	M12x1.75	22	91.0	TSG-200	113	59	RSHG-2006	◆
113	1	24	165	M12x1.75	22	146.0	TSG-200	113	59	RSHG-20012	◆
145	1	24	190	M12x1.75	22	102.0	TSG-250	145	70	RSHG-2502	◆
145	1	24	190	M12x1.75	22	136.0	TSG-250	145	70	RSHG-2506	◆
145	1	24	190	M12x1.75	22	207.0	TSG-250	145	70	RSHG-25012	◆
177	1	19	180	M16x2	30	184.0	TSG-300	177	81	RSHG-3002	◆
177	1	19	180	M16x2	30	232.0	TSG-300	177	81	RSHG-3006	◆
177	1	19	180	M16x2	30	303.0	TSG-300	177	81	RSHG-30012	◆
196	3	27	205	M16x2	30	270.0	TSG-400	196	78	RSHG-4002	◆
196	3	27	205	M16x2	36	330.0	TSG-400	196	78	RSHG-4006	◆
196	3	27	205	M16x2	36	421.0	TSG-400	196	78	RSHG-40012	◆
228	3	27	250	M24x3	38	401.0	TSG-500	228	90	RSHG-5002	◆
228	3	27	250	M24x3	38	480.0	TSG-500	228	90	RSHG-5006	◆
228	3	27	250	M24x3	38	599.0	TSG-500	228	90	RSHG-50012	◆
247	3	27	275	M24x3	38	474.0	TSG-600	247	103	RSHG-6002	◆
247	3	27	275	M24x3	38	565.0	TSG-600	247	103	RSHG-6006	◆
247	3	27	275	M24x3	38	701.0	TSG-600	247	103	RSHG-60012	◆
297	3	27	330	M24x3	38	741.0	TSG-800	297	102	RSHG-8002	◆
297	3	27	330	M24x3	38	880.0	TSG-800	297	102	RSHG-8006	◆
297	3	27	330	M24x3	38	1,058.0	TSG-800	297	102	RSHG-80012	◆
323	3	27	375	M24x3	38	1,062.0	TSG-1000 [†]	323	120	RSHG-10002	◆
323	3	27	375	M24x3	38	1,213.0	TSG-1000 [†]	323	120	RSHG-10006	◆
323	3	27	375	M24x3	38	1,439.0	TSG-1000 [†]	323	120	RSHG-100012	◆

HANDLE TYPES: ♠ WELDED ◆ EYEBOLT ♥ REMOVABLE STRAP HANDLE ♣ THREAD

** Total cylinder collapsed height with optional tilt saddle equals (dim.A - dim.K + dim.K1) [†] Tilt saddle supplied as standard