

B

CYLINDERS



THE RSH-SERIES IS A SINGLE ACTING LOAD RETURN HIGH TONNAGE CYLINDER OFFERING THE LOWEST COLLAPSED HEIGHT.

They are ideally suited for use in civil construction, heavy jacking and other high load applications in confined spaces. These cylinders feature a hard chrome cylinder bore and piston rod for maximum corrosion resistance and bronze overlay piston bearing area to resist side load induced damage. Removable grooved saddle and oil overflow port which restricts piston stroke are standard on all models. TSX tilt saddles are optional. All cylinders in this range have side mounted eye bolts for lifting and positioning.

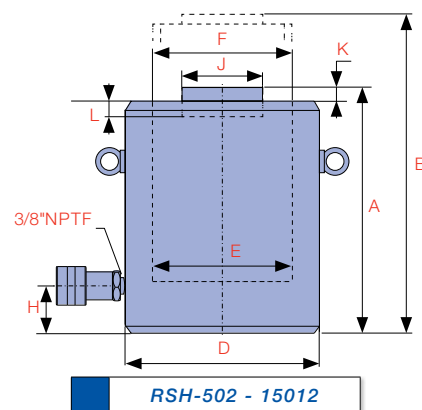

Model Number	Cylinder Capacity ton* / kN	Stroke (mm)	Cylinder Effective Area (cm ²)	Oil Capacity (cm ³)	A Collapsed Height (mm)	B Extended Height (mm)	D Outside Diameter (mm)	E Cylinder Bore Diameter (mm)	F Piston Rod Diameter (mm)
RSH-502	50	496	50	70.8	354	128	178	125	95.0
RSH-504		496	100	70.8	708	178	278	125	95.0
RSH-506		496	150	70.8	1,063	228	378	125	95.0
RSH-508		496	200	70.8	1,417	278	478	125	95.0
RSH-5010		496	250	70.8	1,771	327	577	125	95.0
RSH-5012		496	300	70.8	2,125	378	678	125	95.0
RSH-1002	100	929	50	132.7	663	143	193	165	130.0
RSH-1004		929	100	132.7	1,327	193	293	165	130.0
RSH-1006		929	150	132.7	1,990	243	393	165	130.0
RSH-1008		929	200	132.7	2,653	293	493	165	130.0
RSH-10010		929	250	132.7	3,317	343	593	165	130.0
RSH-10012		929	300	132.7	3,980	392	692	165	130.0
RSH-1502	150	1,390	50	198.5	992	165	215	205	159.0
RSH-1504		1,390	100	198.5	1,985	215	315	205	159.0
RSH-1506		1,390	150	198.5	2,977	265	415	205	159.0
RSH-1508		1,390	200	198.5	3,969	315	515	205	159.0
RSH-15010		1,390	250	198.5	4,961	365	615	205	159.0
RSH-15012		1,390	300	198.5	5,954	414	714	205	159.0

* Nominal Cylinder Capacity in ton - see kN values for actual capacity

HARDENED GROOVED SADDLE

to prevent piston rod damage. Optional tilt saddles available

HARD CHROME PLATED PISTON ROD

for maximum corrosion resistance and cylinder life

BRONZE OVERLAY

on the piston bearing area reduces side load induced damage and extends cylinder life

PISTON ROD WIPER

reduces contaminants

OVERFLOW PORT

serves as a maximum stroke limiter

HARD CHROME PLATED BORE

for maximum corrosion resistance and cylinder life

PARKER

industry standard high flow coupling for compatibility

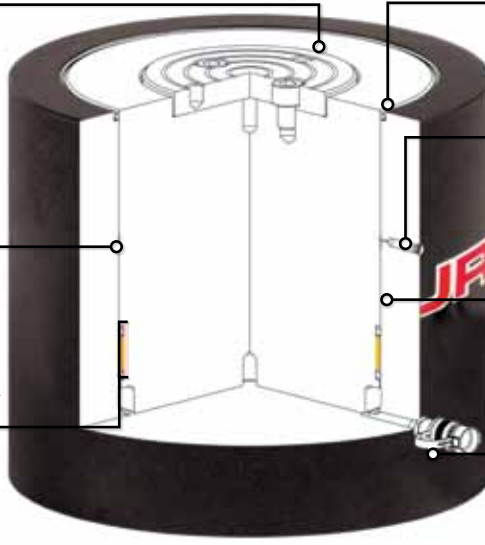

CAPACITY

50 - 1,000 ton

STROKE

50 - 300 mm

MAXIMUM OPERATING PRESSURE

700 bar

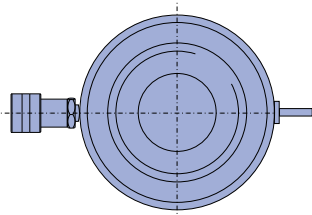
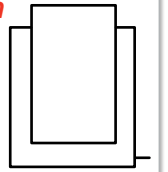

RSH-502 - 15012

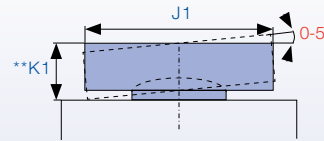

H Base to Advance Port (mm)	J Standard Saddle Diameter (mm)	K Saddle Protrusion from Piston Rod (mm)	L Depth of Piston Rod Hole (mm)	Weight (kg)	Optional Tilt Saddle			Model Number	Handle Type
					Model Number	J1 Diameter (mm)	**K1 Height (mm)		
30	71	2	13	14.0	TSX-100	71	24	RSH-502	◆
30	71	2	13	18.0	TSX-100	71	24	RSH-504	◆
30	71	2	13	23.0	TSX-100	71	24	RSH-506	◆
30	71	2	13	28.0	TSX-100	71	24	RSH-508	◆
30	71	2	13	33.0	TSX-100	71	24	RSH-5010	◆
30	71	2	13	38.0	TSX-100	71	24	RSH-5012	◆
30	71	2	13	24.0	TSX-100	71	24	RSH-1002	◆
30	71	2	13	32.0	TSX-100	71	24	RSH-1004	◆
30	71	2	13	40.0	TSX-100	71	24	RSH-1006	◆
30	71	2	13	49.0	TSX-100	71	24	RSH-1008	◆
30	71	2	13	58.0	TSX-100	71	24	RSH-10010	◆
30	71	2	13	66.0	TSX-100	71	24	RSH-10012	◆
39	130	2	25	43.0	TSX-200	130	20	RSH-1502	◆
39	130	2	25	55.0	TSX-200	130	20	RSH-1504	◆
39	130	2	25	69.0	TSX-200	130	20	RSH-1506	◆
39	130	2	25	82.0	TSX-200	130	20	RSH-1508	◆
39	130	2	25	95.0	TSX-200	130	20	RSH-15010	◆
39	130	2	25	108.0	TSX-200	130	20	RSH-15012	◆

HANDLE TYPES: ♠ WELDED ◆ EYEBOLT ♥ REMOVABLE STRAP HANDLE ♣ THREAD

** Total cylinder collapsed height with optional tilt saddle equals (dim.A - dim.K + dim.K1)

B
CYLINDERS

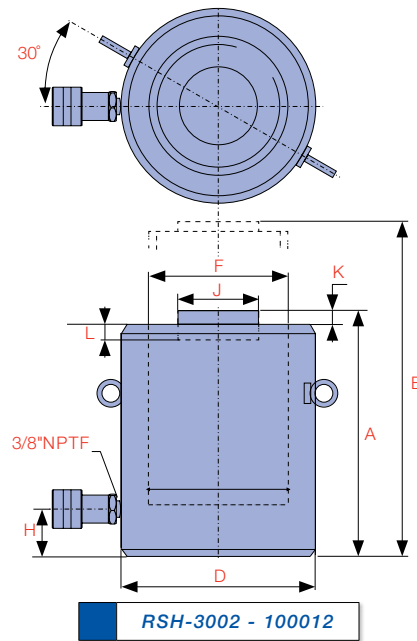
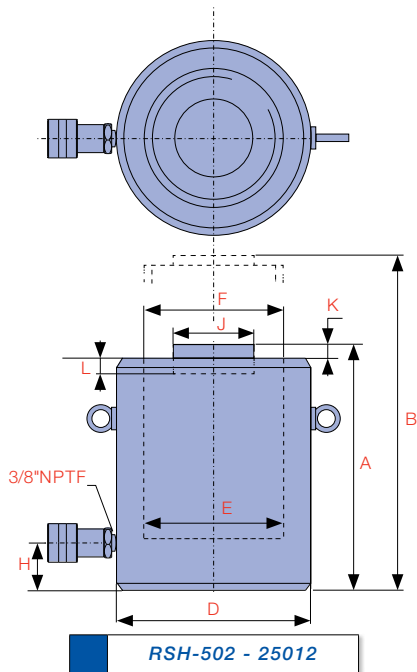

Model Number	Cylinder Capacity ton* / kN	Stroke (mm)	Cylinder Effective Area (cm ²)	Oil Capacity (cm ³)	A Collapsed Height (mm)	B Extended Height (mm)	D Outside Diameter (mm)	E Cylinder Bore Diameter (mm)	F Piston Rod Diameter (mm)
RSH-2002	200	1,859	50	265.5	1,327	193	243	235	183.9
RSH-2006		1,859	150	265.5	3,982	293	443	235	183.9
RSH-20012		1,859	300	265.5	7,964	443	743	235	183.9
RSH-2502	250	2,562	50	365.9	1,830	193	243	275	215.9
RSH-2506		2,562	150	365.9	5,489	293	443	275	215.9
RSH-25012		2,562	300	365.9	10,977	443	743	275	215.9
RSH-3002	300	3,193	50	455.9	2,280	235	285	310	241.0
RSH-3006		3,193	150	455.9	6,839	335	485	310	241.0
RSH-30012		3,193	300	455.9	13,678	485	785	310	241.0
RSH-4002	400	3,919	50	559.6	2,798	265	315	350	267.0
RSH-4006		3,919	150	559.6	8,394	365	515	350	267.0
RSH-40012		3,919	300	559.6	16,789	515	815	350	267.0
RSH-5002	500	5,118	50	730.7	3,654	295	345	400	305.1
RSH-5006		5,118	150	730.7	10,961	395	545	400	305.1
RSH-50012		5,118	300	730.7	21,922	545	845	400	305.1
RSH-6002	600	5,983	50	854.3	4,272	310	360	430	329.9
RSH-6006		5,983	150	854.3	12,815	410	560	430	329.9
RSH-60012		5,983	300	854.3	25,630	560	860	430	329.9
RSH-8002	800	8,238	50	1,176.3	5,881	355	405	505	387.1
RSH-8006		8,238	150	1,176.3	17,644	455	605	505	387.1
RSH-80012		8,238	300	1,176.3	35,289	605	905	505	387.1
RSH-10002	1,000	10,260	50	1,465.7	7,329	385	435	560	432.1
RSH-10006		10,260	150	1,465.7	21,985	485	635	560	432.1
RSH-100012		10,260	300	1,465.7	43,970	635	935	560	432.1

* Nominal Cylinder Capacity in ton - see kN values for actual capacity

Did you know...

RPLC-Series low height locking collar cylinders offer extremely low collapsed height and the ability to **mechanically support a load**.

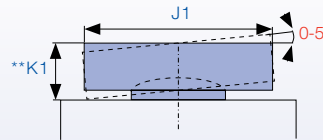

H Base to Advance Port (mm)	J Standard Saddle Diameter (mm)	K Saddle Protrusion from Piston Rod (mm)	L Depth of Piston Rod Hole (mm)	Weight (kg)	Optional Tilt Saddle			Model Number	Handle Type
					Model Number	J1 Diameter (mm)	**K1 Height (mm)		
50	130	2	25	66	TSX-200	130	20	RSH-2002	◆
50	130	2	25	101	TSX-200	130	20	RSH-2006	◆
50	130	2	25	154	TSX-200	130	20	RSH-20012	◆
50	150	2	25	90	TSX-250	150	21	RSH-2502	◆
50	150	2	25	137	TSX-250	150	21	RSH-2506	◆
50	150	2	25	208	TSX-250	150	21	RSH-25012	◆
59	139	5	25	137	TSX-300	195	75	RSH-3002	◆
59	139	5	25	198	TSX-300	195	75	RSH-3006	◆
59	139	5	25	288	TSX-300	195	75	RSH-30012	◆
70	159	5	25	200	TSX-400	225	85	RSH-4002	◆
70	159	5	25	275	TSX-400	225	85	RSH-4006	◆
70	159	5	25	390	TSX-400	225	85	RSH-40012	◆
80	179	5	25	289	TSX-500	250	91	RSH-5002	◆
80	179	5	25	390	TSX-500	250	91	RSH-5006	◆
80	179	5	25	540	TSX-500	250	91	RSH-50012	◆
85	194	5	25	350	TSX-600	275	96	RSH-6002	◆
85	194	5	25	465	TSX-600	275	96	RSH-6006	◆
85	194	5	25	640	TSX-600	275	96	RSH-60012	◆
100	224	5	25	549	TSX-800	320	123	RSH-8002	◆
100	224	5	25	709	TSX-800	320	123	RSH-8006	◆
100	224	5	25	950	TSX-800	320	123	RSH-80012	◆
110	249	5	25	729	TSX-1000	360	136	RSH-10002	◆
110	249	5	25	921	TSX-1000	360	136	RSH-10006	◆
110	249	5	25	1,210	TSX-1000	360	136	RSH-100012	◆

HANDLE TYPES: ♣ WELDED ◆ EYEBOLT ♥ REMOVABLE STRAP HANDLE ♠ THREAD

** Total cylinder collapsed height with optional tilt saddle equals (dim.A - dim.K + dim.K1)