

THE **PEMH & PAMH PUMPS** ARE PERFECTLY DESIGNED FOR BOLT TENSIONING APPLICATIONS UTILISING DURAPAC DBT SERIES BOLT TENSIONERS AT 1,500 BAR.

The PEMH0543 is an electric two speed pump with a 2.8 metre remote hand pendant. The PAMH1514 is a light weight single acting pump suited to applications where air is the preferred power source.

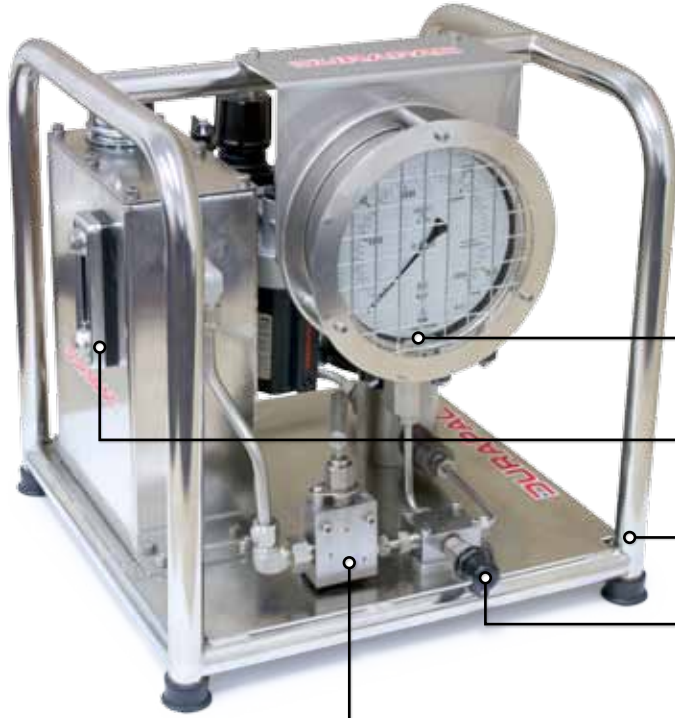

LIQUID FILLED PRESSURE GAUGE

range is 0-1,600 bar / 0-23,000 psi

SITE GLASS

incorporating temperature gauge

STAINLESS STEEL BASE AND FRAME

resist corrosion and allows for easy handling

OIL OUTLET

fitted with a 1/4" DBT116M quick release nipple

PRESSURE RELEASE VALVE



FILTER, REGULATOR & LUBRICATOR WITH GAUGE

are supplied on the air inlet

STAINLESS STEEL RESERVOIR

5.6 litres of useable oil

RESERVOIR ON/OFF VALVE

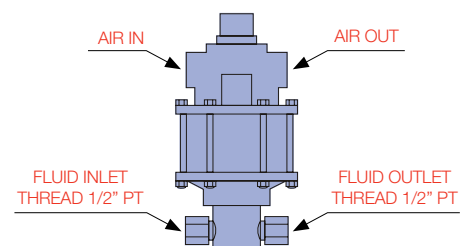

Model Number	Used with Cylinder	Pressure Rating (bar)	Compression Ratio	Oil Flow (cm ³ /stroke)	Air Pressure Range (bar)	Air Consumption (Lpm)	Oil Port Thread	Oil Capacity (L)	Dry Weight (kg)
PAMH1514	S/A	1,500	1:310	1.2	5-7	793	G 1/4"	5.6	25

DURAPAC PEMH & PAMH | SERIES

WWW.DURAPAC.COM

BOLT TENSIONING POWER UNITS

E

BOLTING SOLUTIONS

ELECTRIC MOTOR

0.5 kW/220 volt 50-60 Hz
universal motor 6.0 amps

LIQUID FILLED PRESSURE GAUGE

range is 0-2,500 bar / 0-35,000 psi

ADJUSTABLE TORQUE CONTROL

for accurate torque settings

PRESSURE RELEASE LEVER

OIL OUTLET

fitted with a 1/4" DBT116M
quick release nipple

2.8M REMOTE PENDANT

through a 24 volt transformer
for safety. Incorporates
motor ON/OFF button



POWER REQUIREMENT

Electric 220 Volt 50-60 Hz (two speed pump)

AIR REQUIREMENT

Air 793 Lpm @ 7 bar (single speed pump)

MAXIMUM OPERATING PRESSURE

1,500 bar

SITE GLASS

incorporating
temperature gauge

RESERVOIR

capacity 4L

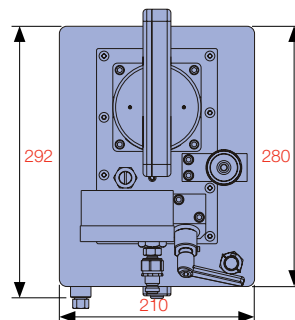
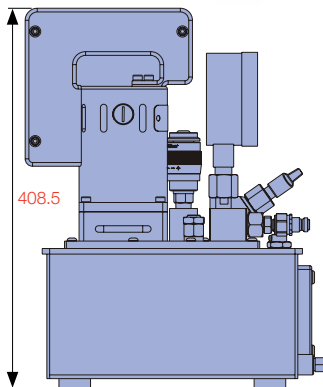

Model Number	kW	Voltage	Hz	Amps	Usable oil Capacity (L)	Maximum Pressure Rating (bar)	Flow Rate (Lpm)		Remote Pendant Function 2.8 mtr	Weight (kg)
							30 bar	1,500 bar		
PEMH0543	0.50	220	50/60	6	4	1,500	2	0.13	ON/OFF	24