

C

PUMPS

THE *DPA-SERIES* OF AIR DRIVEN HYDRAULIC PUMPS ARE A FIELD PROVEN ECONOMICAL CHOICE OF POWER SOURCE FOR RUNNING SMALL TO MEDIUM HYDRAULIC CYLINDERS AND TOOLS WHEN COMPRESSED AIR IS AVAILABLE.

All models have a maximum working pressure of 700 bar and metal oil reservoirs for strength and durability. A convenient carry handle is built into the treadle and all pumps are supplied pre-filled with oil and ready for immediate use.



## FEATURES



- Choice of 1.5, 3.8 & 7.5 L usable oil reservoirs



- Remote actuation for adv/hold/retract functions



- 3 position treadle for adv/hold/retract functions



- Convenient carry handle included



- Dust cover protection for the release control valve



- 4 way directional control valve to operate double acting cylinders

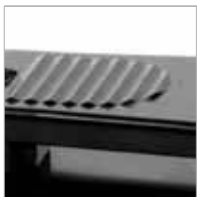

- Release detent function enhances productivity



- Recommended air pressure range 4-12 bar



- 1.5 L high strength, reinforced alloy oil reservoir. 3.8 & 7.5 L reservoirs are made from durable steel



OIL CAPACITY

**1.5 - 7.5 L**

AIR PRESSURE RANGE

**4 - 12 bar**

MAXIMUM OPERATING PRESSURE

**700 bar**

## PRESSURE VS FLOW RATE

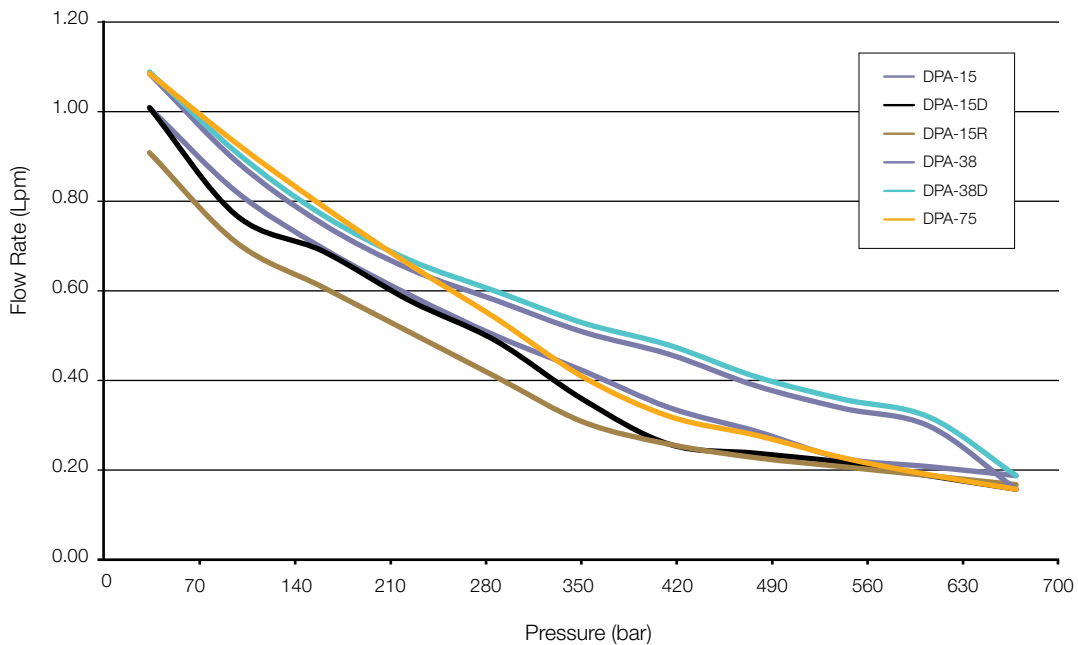

C  
PUMPS

DPA-75



DPA-38



DPA-15



THE **DPA-15 (1.5 L)**, **DPA-38 (3.8 L)** AND **DPA-75 (7.5 L)** MODELS ARE THE STANDARD WORK HORSES OF THE RANGE.

Each has a 3 position treadle with advance/hold/retract functions, dust cover protection for the release control valve and a reinforced metal oil reservoir.

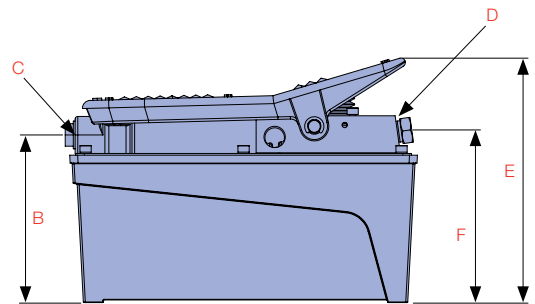
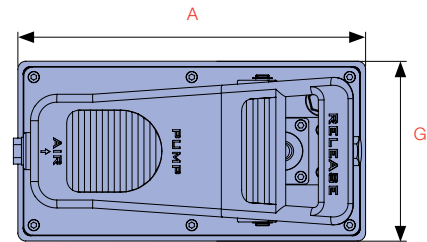

DPA-15

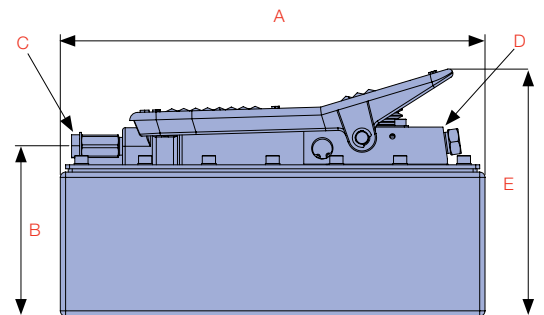
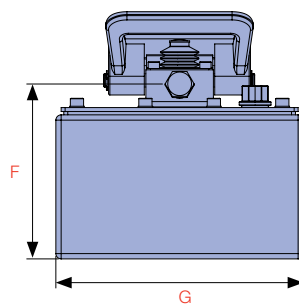

DPA-38 & DPA-75

Model Number	Used with Cylinder	Usable Oil Capacity (cc)	Pressure Rating (bar)	Output Flow Rate (cm <sup>3</sup> /min)		Air Pressure Range (bar)	Dimension (mm)						Weight (kg)	
				No load	Load		A	B	C	D	E	F		G
DPA-15	S/A	1,500	700	1,000	180	4-12	263	127	1/4"NPT	3/8"NPTF	185	131	136	8.2
DPA-15D	D/A	1,500	700	1,000	150	4-12	263	127	1/4"NPT	3/8"NPTF	203	136	136	8.7
DPA-15R	S/A	1,500	700	900	160	4-12	279	160	1/4"NPT	3/8"NPTF	204	130	136	8.8
DPA-38	S/A	3,800	700	1,075	150	4-12	321	129	1/4"NPT	3/8"NPTF	187	133	187	12.3
DPA-38D	D/A	3,800	700	1,075	180	4-12	321	129	1/4"NPT	3/8"NPTF	204	133	187	13.5
DPA-75	S/A	7,550	700	1,075	150	4-12	321	155	1/4"NPT	3/8"NPTF	212	159	255	17.4

THE **DPA-15R** IS A REMOTE EQUIPPED AIR DRIVEN HYDRAULIC PUMP AND IS IDEALLY SUITED WHEN A REMOTE ACTUATION OF THE PUMP IS REQUIRED.

The pump will operate small to medium sized single acting cylinders and is supplied with a 3 metre long hand lead with advance-hold-retract button on the remote.



OIL CAPACITY  
**1.5 - 7.5 L**

AIR PRESSURE RANGE  
**4 - 12 bar**

MAXIMUM OPERATING PRESSURE  
**700 bar**

**DPA-15R**

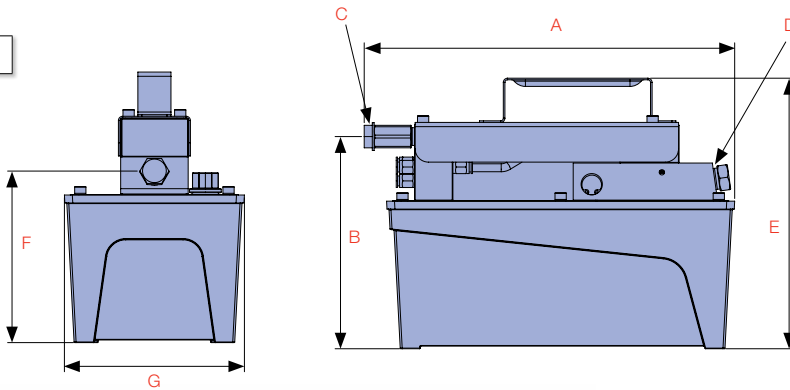

THE **DPA-15D** AND **DPA-38D** ARE AIR DRIVEN HYDRAULIC PUMPS WITH A 4 WAY/3 POSITION MANUAL DIRECTIONAL CONTROL VALVE.

They are designed for operating double acting, small to medium sized cylinders and tools.

**DPA-15D & DPA-38D**

