

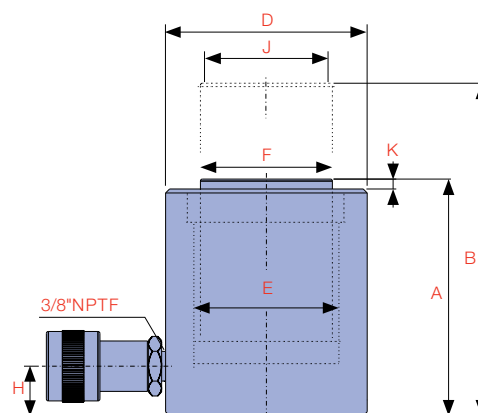

THE **AR-SERIES** IS A LIGHTWEIGHT HIGH STRENGTH ALUMINIUM SPRING RETURN CYLINDER THAT IS IDEAL FOR USE IN APPLICATIONS WHERE WEIGHT AND PORTABILITY ARE PARAMOUNT.

A special anodising treatment on the piston rod, cylinder bore and body resists damage and extends cylinder life. AR-Series cylinders can be used in applications such as axle correction, bridge jacking, machinery maintenance and other non production applications.



Model Number	Cylinder Capacity ton* / kN	Stroke (mm)	Cylinder Effective Area (cm ²)	Oil Capacity (cm ³)	A Collapsed Height (mm)	B Extended Height (mm)	D Outside Diameter (mm)	
AR-302	30	293	50	41.9	213	168	218	114
AR-304		293	101	41.9	426	229	330	114
AR-306		293	152	41.9	639	270	422	114
AR-308		293	203	41.9	852	320	523	114
AR-3010		293	254	41.9	1,065	371	625	114
AR-502	50	498	50	71.2	360	168	218	139
AR-504		498	101	71.2	723	229	330	139
AR-506		498	152	71.2	1,085	270	422	139
AR-508		498	203	71.2	1,445	320	523	139
AR-5010		498	254	71.2	1,809	371	625	139
AR-752	75	678	50	96.8	492	168	218	165
AR-754		678	101	96.8	985	229	330	165
AR-756		678	152	96.8	1,477	270	422	165
AR-758		678	203	96.8	1,969	320	523	165
AR-7510		678	254	96.8	2,463	371	625	165
AR-1002	100	931	50	133.0	675	168	218	203
AR-1004		931	101	133.0	1,351	229	330	203
AR-1006		931	152	133.0	2,027	270	422	203
AR-1008		931	203	133.0	2,702	320	523	203
AR-10010		931	254	133.0	3,379	371	625	203

PISTON ROD WIPER

reduces contaminants

PISTON ROD

has a special anodising treatment to resist damage

HANDLE

is threaded and removable

CYLINDER BORE

has a special anodising treatment to resist damage

BEARING SURFACE

large area with balancing and lubricating grooves for protection against side loading

HARDENED STEEL GROOVED SADDLE

to prevent piston rod damage. Optional tilt saddles available

GLAND NUT

aluminium/bronze withstands full dead end loading

RETURN SPRING

heavy duty for faster retraction

LIGHTWEIGHT

high strength aluminium materials

PARKER

industry standard high flow coupling for compatibility

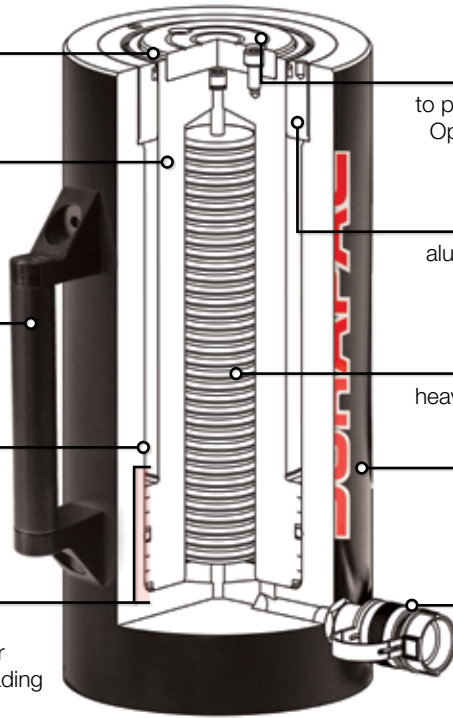

CAPACITY

30 - 150 ton

STROKE

50 - 254 mm

MAXIMUM OPERATING PRESSURE

700 bar

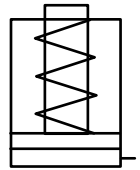

B

CYLINDERS

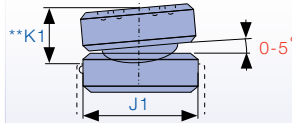

E Cylinder Bore Diameter (mm)	F Piston Rod Diameter (mm)	H Base to Advance Port (mm)	J Standard Saddle Diameter (mm)	K Saddle Protrusion from Piston Rod (mm)	Optional Tilt Saddle			Weight (kg)
					Model Number	J1 Diameter (mm)	**K1 Height (mm)	
73.2	63.5	38	51	3	-	-	-	5.0
73.2	63.5	38	51	3	-	-	-	6.8
73.2	63.5	38	51	3	-	-	-	7.1
73.2	63.5	38	51	3	-	-	-	9.0
73.2	63.5	38	51	3	-	-	-	11.3
92.2	79.4	38	64	3	ATS-50	60	30	7.4
92.2	79.4	38	64	3	ATS-50	60	30	9.6
92.2	79.4	38	64	3	ATS-50	60	30	11.4
92.2	79.4	38	64	3	ATS-50	60	30	13.6
92.2	79.4	38	64	3	ATS-50	60	30	15.4
111.3	98.4	38	76	3	ATS-75	73	30	10.0
111.3	98.4	38	76	3	ATS-75	73	30	13.0
111.3	98.4	38	76	3	ATS-75	73	30	15.8
111.3	98.4	38	76	3	ATS-75	73	30	19.0
111.3	98.4	38	76	3	ATS-75	73	30	22.7
130.3	108.0	38	89	3	ATS-100	82	30	16.0
130.3	108.0	38	89	3	ATS-100	82	30	19.4
130.3	108.0	38	89	3	ATS-100	82	30	23.0
130.3	108.0	38	89	3	ATS-100	82	30	27.2
130.3	108.0	38	89	3	ATS-100	82	30	30.6



Did you know...

Durapac has a range of aluminium lightweight pumps to suit the **aluminium cylinder range**.



P-2200A



Caution...

Lightweight **aluminium cylinders** are **not** designed for production applications. Refer to Durapac for information relating to high cycle applications.

** Total cylinder collapsed height with optional tilt saddle equals (dim.A - dim.K + dim.K1)

AR-SERIES CONTINUED...

B
CYLINDERS

Model Number	Cylinder Capacity ton* / kN	Stroke (mm)	Cylinder Effective Area (cm ²)	Oil Capacity (cm ³)	A Collapsed Height (mm)	B Extended Height (mm)	D Outside Diameter (mm)
AR-1502	150	1,386	50	198.0	1,005	193	254
AR-1504		1,386	101	198.0	2,011	244	254
AR-1506		1,386	152	198.0	3,016	295	254
AR-1508		1,386	203	198.0	4,020	345	254
AR-15010		1,386	254	198.0	5,027	397	254

ARHS | SERIES



EXCEEDS
ANSI/ASME B30.1
SAFETY
STANDARDS

THE ARHS-SERIES IS A SPRING RETURN HOLLOW PISTON ROD ALUMINIUM CYLINDER.

The hollow piston allows for a rod or cable to be inserted through the entire body length. They can be used in tensioning, load testing, bush extracting and maintenance applications where weight and portability are paramount. All cylinders incorporate a bolt on removable aluminium base plate for extra protection.

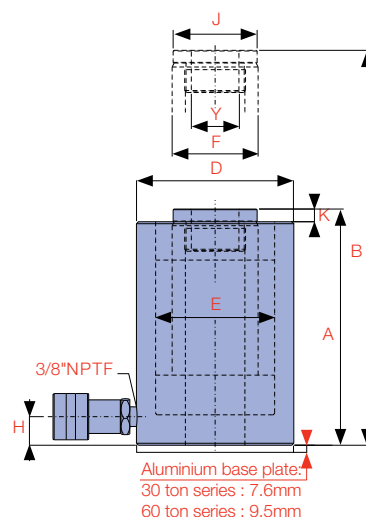

Model Number	Cylinder Capacity ton* / kN	Stroke (mm)	Cylinder Effective Area (cm ²)	Oil Capacity (cm ³)	A Collapsed Height (mm)	B Extended Height (mm)	D Outside Diameter (mm)
ARHS-303	30	326	75	46.5	361	219	139
ARHS-306		326	152	46.5	721	296	139
ARHS-603	60	555	75	79.3	606	336	190
ARHS-606		555	152	79.3	1,213	337	190

* Nominal Cylinder Capacity in ton - see kN values for actual capacity

E Cylinder Bore Diameter (mm)	F Piston Rod Diameter (mm)	H Base to Advance Port (mm)	J Standard Saddle Diameter (mm)	K Saddle Protrusion from Piston Rod (mm)	Optional Tilt Saddle			Weight (kg)
					Model Number	J1 Diameter (mm)	**K1 Height (mm)	
158.9	127.0	38	114	3	ATS-150	108	46	24.8
158.9	127.0	38	114	3	ATS-150	108	46	30.6
158.9	127.0	38	114	3	ATS-150	108	46	36.6
158.9	127.0	38	114	3	ATS-150	108	46	43.1
158.9	127.0	38	114	3	ATS-150	108	46	50.8



Caution...

Lightweight **aluminium cylinders** are **not** designed for production applications. Refer to Durapac for information relating to high cycle applications.

B
CYLINDERS

ARHS | SERIES

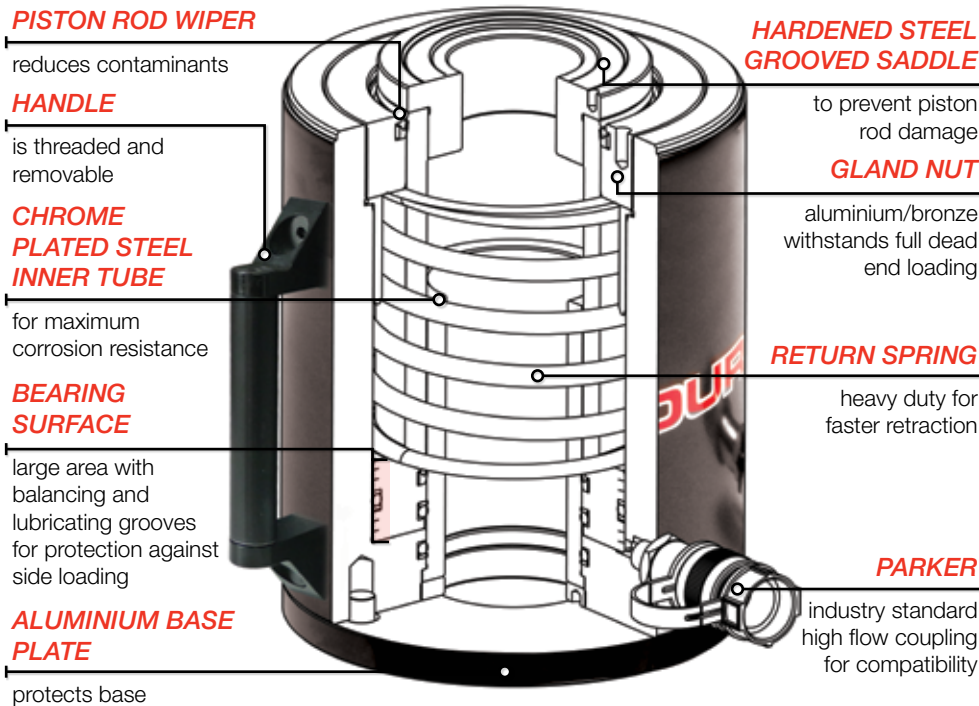

CAPACITY
30 - 60 ton

STROKE
75 - 152 mm

MAXIMUM OPERATING PRESSURE
700 bar

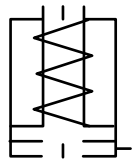

E Cylinder Bore Diameter (mm)	F Piston Rod Diameter (mm)	H Base to Advance Port (mm)	J Standard Saddle Diameter (mm)	K Saddle Protrusion from Piston Rod (mm)	Y Centre Hole Diameter (mm)	Weight (kg)
89.0	63.5	25	64	10	32.3	9.9
89.0	63.5	25	64	10	32.3	13.6
120.8	92.1	25	92	13	54.0	19.0
120.8	92.1	25	92	13	54.0	24.9



Caution...

Protective aluminium base plate protects the cylinder and should **not** be removed. **Threaded base holes** should **not** be used for any other purpose.

** Total cylinder collapsed height with optional tilt saddle equals (dim.A - dim.K + dim.K1)