



"Makin' the Hard Jobs Easy"

# LITHIUM SERIES II



THE MOST AWARD-WINNING  
ELECTRIC TORQUE MULTIPLIER

(See page 3 for details.)

## LITHIUM SERIES® II Electric Torque Tool

The LITHIUM SERIES® II Electric Torque Tool is the next revolution in bolting technology redesigned from the ground up with expanded functionality, greater durability, and intuitive usability. This lightweight 36 Volt battery powered tool, with capacity up to 5,000 ft-lbs, is the ultimate solution for strength and portability in industrial bolting jobs worldwide. This tool is compatible with conventional sockets, the HYTORC Washer, and the HYTORC Nut.

### FEATURE LIST



#### TorcSense™ Technology

#### Brushless Motor

#### All Aluminum Housing

- High Strength Gearbox
- Nickel Plated
- Rear Shock Guard
- Work Light
- High Resolution Display

#### Directional Switch

- Snug Function

#### Intuitive User Interface

- Access Levels
- Data Acquisition

#### Bluetooth Wireless Technology

- Expanded Job Data Management
- Advanced Bolting Features

#### Compatible with HYTORC Nut

#### Compatible with HYTORC Washer

Look inside for detailed information about the highlighted features above.



"Makin' the Hard Jobs Easy"

# LITHIUM SERIES II

## TESTIMONIAL

"I HAVE BEEN AROUND PLENTY OF BOLTING TOOLS, SEEN MANY TOOLS USED. BUT THIS IS REALLY COOL! IT'S LIGHTER THAN I EXPECTED, IT'S REALLY FOOL PROOF, AND SO SIMPLE THAT ANYONE CAN GET THE JOB DONE. THE GUYS ARE GOING TO BE ABLE TO WORK LONGER AND SAFER, WHILE STILL GETTING THE JOB DONE RIGHT. I LOVE IT!"

**Kyle Chambers**  
Texas Quality Assurance



### TorcSense™ Technology



A direct torque measurement system utilizing a strain based transducer in a closed loop monitoring system provides more repeatable torque and enables advanced bolting features.

### BRUSHLESS 36V DC MOTOR



The tool uses an all new 36V brushless DC motor which runs cooler, quieter, and has significantly longer life.

### INTUITIVE USER INTERFACE



The home screen and menu structure have been redesigned with all new icons, indicators, and simple navigation layout making the tool intuitive and simple to use.



"Makin' the Hard Jobs Easy"

# LITHIUM SERIES II



## BLUETOOTH WIRELESS TECHNOLOGY

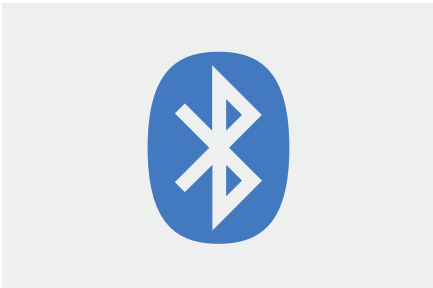

Now standard with Bluetooth wireless technology, the tool makes data transfer easier than ever! Job data and tool firmware upgrades can now be performed wirelessly.

## ALL-ALUMINUM HOUSING



The new all-aluminum housing vastly improves impact resistance and durability protecting the tool's vital components. The gearbox is also nickel plated for corrosion resistance.

## MULTIPLE TOOL CONFIGURATIONS



The tool is easily configured for conventional sockets and reactions arms, the HYTORC Washer System, and precision mechanical tensioning with the HYTORC Nut.

## DIRECTIONAL SWITCH



Conveniently located near the trigger, the sliding directional switch can quickly change drive direction from tighten and loosen with a simple push of a button.

## AWARD-WINNING DESIGN

### PRO TOOL INNOVATION AWARD 2019



This award honors the LITHIUM SERIES II Tool as the very best and brightest industrial power tool available.

### GOOD DESIGN AWARD 2019

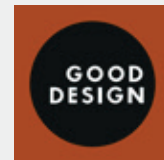

This award honors the LITHIUM SERIES II Tool as the leader in design with innovation that has pushed the envelope in the world marketplace.

### SPOTLIGHT ON NEW TECHNOLOGY 2019



This award recognizes the LITHIUM SERIES II Tool as a new and innovative technology that will make a major impact in the oil and gas industry.

## HY-CARE



**HY-CARE Service Plans\*** provide peace of mind protection and offer a no deductible plan to protect you from unexpected bolting equipment repair costs and downtime after your standard equipment warranty expires. On average, a tool with HY-CARE lasts up to five times longer in service. Never settle for less.



"Makin' the Hard Jobs Easy"

# LITHIUM SERIES II

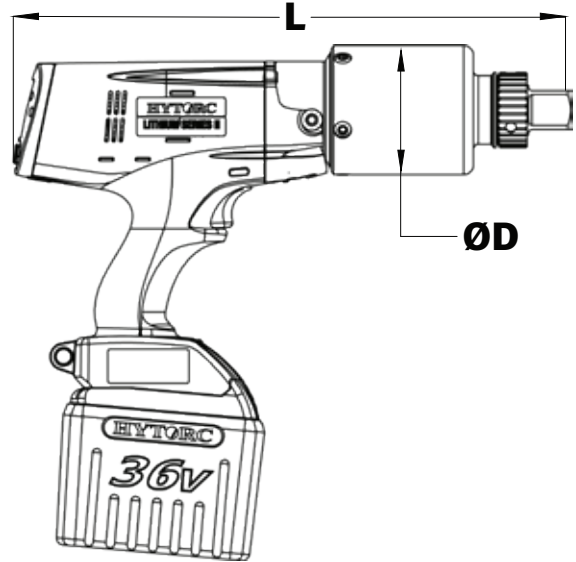
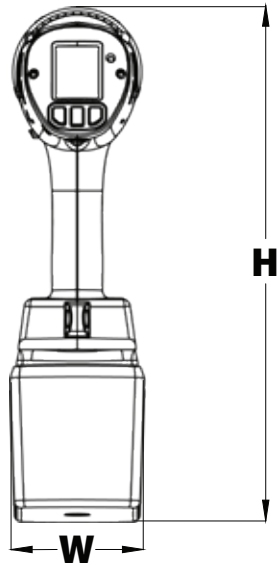

LEGEND: H = HEIGHT W = WIDTH L = LENGTH ØD = DIAMETER

| CONFIGURATIONS | H    | W   | L    | D   | DRIVE | WEIGHT<br>W/ BATTERY | SNUG         |              | TORQUE       |              |          |
|----------------|------|-----|------|-----|-------|----------------------|--------------|--------------|--------------|--------------|----------|
|                |      |     |      |     |       |                      | ft-lbs (Min) | ft-lbs (Max) | ft-lbs (Min) | ft-lbs (Max) |          |
| IMPERIAL       |      |     |      |     |       | in.                  | lbs.         |              |              |              |          |
| LST-0700       | 12.9 | 3.5 | 11.4 | 2.6 | 3/4   | 11.7                 | 35           | 149          | 150          | 700          |          |
| LST-1200       | 12.9 | 3.5 | 11.7 | 2.6 | 3/4   | 12.0                 | 60           | 199          | 200          | 1,200        |          |
| LST-2000       | 13.2 | 3.5 | 13.9 | 3.2 | 1     | 16.6                 | 100          | 324          | 325          | 2,000        |          |
| LST-3000       | 13.3 | 3.5 | 14.4 | 3.4 | 1     | 17.7                 | 150          | 499          | 500          | 3,000        |          |
| LST-5000       | 16.6 | 4.0 | 15.4 | 4.0 | 1-1/2 | 22.4                 | 200          | 799          | 800          | 5,000        |          |
| METRIC         |      |     |      |     |       | mm                   | kg           | Nm (Min)     | Nm (Max)     | Nm (Min)     | Nm (Max) |
| LST-0700       | 328  | 89  | 290  | 66  | 3/4   | 5.3                  | 47           | 202          | 203          | 949          |          |
| LST-1200       | 328  | 89  | 297  | 66  | 3/4   | 5.5                  | 81           | 270          | 271          | 1627         |          |
| LST-2000       | 335  | 89  | 353  | 81  | 1     | 7.5                  | 135          | 439          | 440          | 2712         |          |
| LST-3000       | 338  | 89  | 366  | 86  | 1     | 8.0                  | 203          | 676          | 677          | 4067         |          |
| LST-5000       | 422  | 102 | 391  | 102 | 1-1/2 | 10.2                 | 270          | 1083         | 1085         | 6779         |          |

## COMPLETE KIT CONTENTS

- LITHIUM SERIES II Tool
- Reaction Arm
- Storage Case
- 36V Battery
- Battery Charging System
- Side Handle
- Calibration Certificate
- Operation Manual

## LST

**Model:**  
LITHIUM SERIES TOOL

**Capacity:**  
Available: 0700, 1200,  
2000, 3000, 5000

**Communication:**  
Blank: Bluetooth Communication  
U: USB Only

## Examples:

1. LST-0700 standard tool, 700 ft-lb capacity, with Bluetooth Communication
2. LST-0700-U standard tool, 700 ft-lb capacity, without Bluetooth - USB Connection Only