



TOOL HIRE



TH70 RAIL TENSOR

Offering you the benefit of lightweight elements, the Geismar TH70 can be assembled and disassembled by 2 operators in only a few minutes. Designed to work with all types of rails and in all environments the TH70 is used to stretch and pretension lengths of rail during the installation and repair process.

Scan QR Code for more info:



Made in France and approved by Kiwirail for track use in NZ

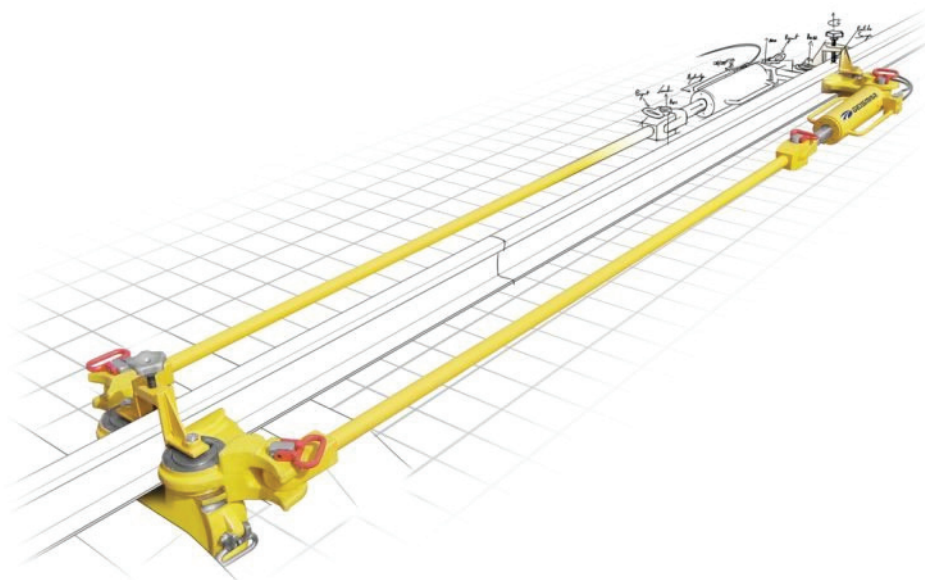

| | |
|---|--|
| Engine(s) Thermic, electric & manual | Certification SNCF, Renfe... |
| Gauges From 900 to 1,676 mm From 35 to 66 in. | Mass From 260 to 295 kg From 573 to 650 lbs |
| Stroke Up to 109 t | Mass of the heaviest element From 33 kg to 45 kg From 73 to 99 lbs |
| Ram stroke 380 mm / 15 in. | |



"Makin' the Hard Jobs Easy"