

OIL CAPACITY  
**1.5 - 7.5 L**

AIR PRESSURE RANGE  
**4-12 bar**

MAXIMUM OPERATING PRESSURE  
**700 bar**

THE **DPA-15D** IS AN AIR DRIVEN HYDRAULIC PUMP WITH A 4 WAY/3 POSITION MANUAL DIRECTIONAL CONTROL VALVE.

It is designed for operating double acting, small to medium sized cylinders and tools.

THE **DPA-15R** IS A REMOTE EQUIPPED AIR DRIVEN HYDRAULIC PUMP AND IS IDEALLY SUITED WHEN A REMOTE ACTUATION OF THE PUMP IS REQUIRED.

The pump will operate small to medium sized single acting cylinders and is supplied with a 3 metre long hand lead with advance-hold-retract button on the remote.

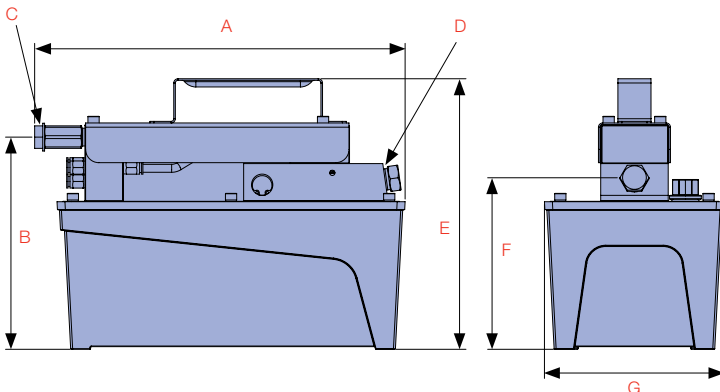
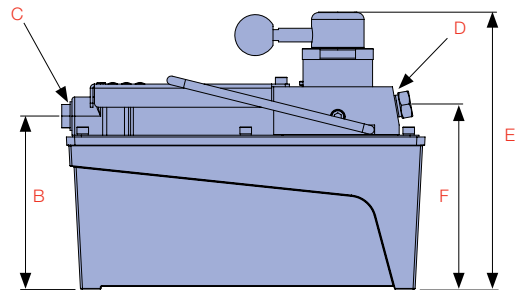
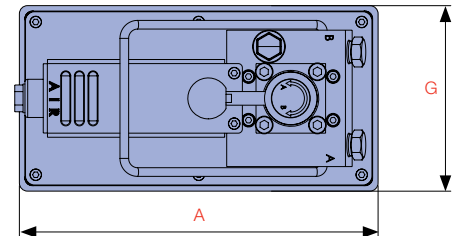

**DPA-15R**

**DPA-15D**

Model Number	Used with Cylinder	Usable Oil Capacity (cc)	Pressure Rating (bar)	Output Flow Rate (cm <sup>3</sup> /min)		Air Pressure Range (bar)	Dimension (mm)							Weight (kg)
				No load	Load		A	B	C	D	E	F	G	
DPA-15D	D/A	1,500	700	1,127	70	4-12	263	127	1/4"NPT	3/8"NPTF	203	136	136	8.7
DPA-15R	S/A	1,500	700	630	240	4-12	279	160	1/4"NPT	3/8"NPTF	204	130	136	8.8